

## Stacked Metallized PPS Film Chip Capacitor

Type: **ECHU(C)**

Stacked metallized PPS film as dielectric with simple mold-less construction

### ■ Features

- Small in size
- Low loss and excellent frequency characteristics
- For reflow soldering
- RoHS directive compliant

### ■ Recommended Applications

- Time-constant
- Filtering
- Oscillation and resonance
- Resonance circuit for LCD backlight inverter unit

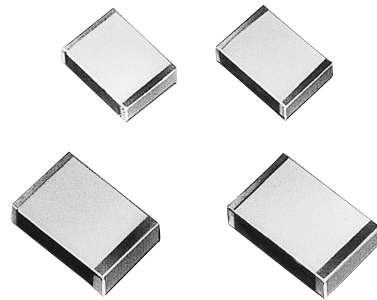

### ■ Explanation of Numbers

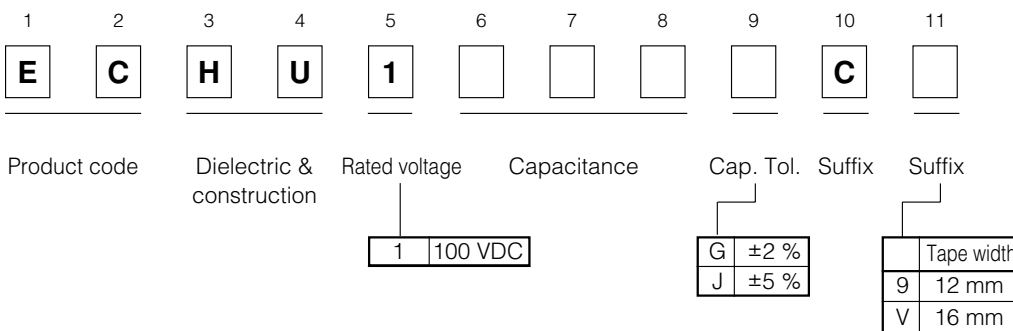

### ■ Specifications

Category temp. range (Including temperature-rise on unit surface)	-55 °C to +105 °C
Rated voltage	100 VDC
Capacitance range	0.010 μF to 0.22 μF(E12)
Capacitance tolerance	±2 %(G), ±5 %(J)
Withstand voltage	Between terminals : Rated volt. (VDC)×150 % 60 s
Dissipation factor (tanδ)	tan δ ≤0.6 % (20 °C, 1 kHz)
Insulation resistance (IR)	IR ≥3000 MΩ(20 °C, 100 VDC, 60 s)
Soldering conditions	Reflow soldering : 260 °C max. and 95 s max. at more than 220 °C (Temp. at cap. Surface)

\* In case of applying voltage in alternating current (50 Hz or 60 Hz sine wave) to a capacitor with DC rated voltage, please refer to the page of "Permissible voltage (R.M.S) in alternating current corresponding to DC rated voltage".

### Construction

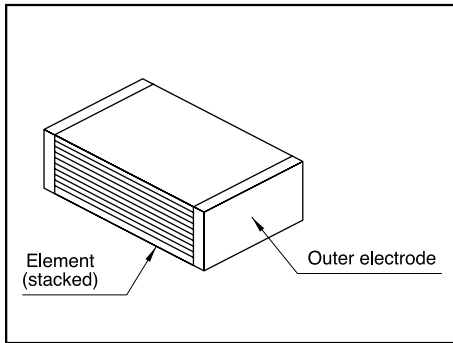

### Dimensions in mm (not to scale)

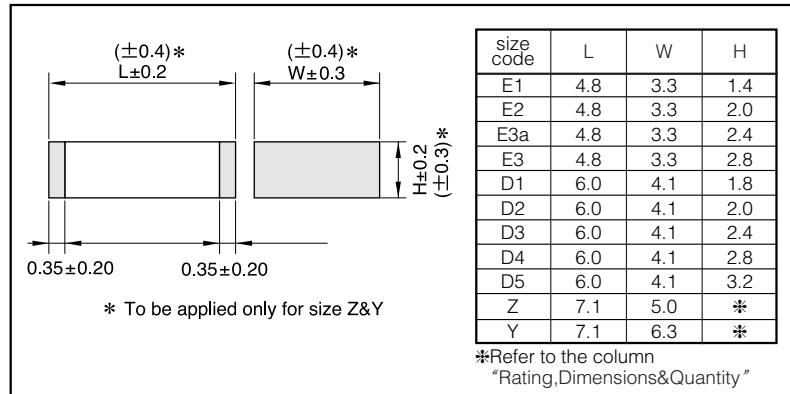

### Taping Specification for Automatic Mounting

Refer to the page of taping specifications.

### Rating, Dimensions & Quantity/Reel

● Capacitance tolerance:  $\pm 2\%$  (G),  $\pm 5\%$  (J)

Cap.( $\mu$ F)	Rated volt. 100 VDC					Q'ty
	Part No.	Dimensions (mm)			Size Code	
		L	W	H		
0.010	ECHU1103□C9	4.8	3.3	1.4	E1	3000
0.012	ECHU1123□C9	4.8	3.3	1.4	E1	
0.015	ECHU1153□C9	4.8	3.3	2.0	E2	
0.018	ECHU1183□C9	4.8	3.3	2.0	E2	
0.022	ECHU1223□C9	4.8	3.3	2.4	E3a	2000
0.027	ECHU1273□C9	4.8	3.3	2.8	E3	
0.033	ECHU1333□C9	6.0	4.1	1.8	D1	3000
0.039	ECHU1393□C9	6.0	4.1	2.0	D2	
0.047	ECHU1473□C9	6.0	4.1	2.4	D3	
0.056	ECHU1563□C9	6.0	4.1	2.8	D4	2000
0.068	ECHU1683□C9	6.0	4.1	3.2	D5	
0.082	ECHU1823□C9	7.1	5.0	2.8	Z	1500
0.10	ECHU1104□C9	7.1	5.0	3.0	Z	
0.12	ECHU1124□C9	7.1	5.0	3.4	Z	
0.15	ECHU1154□CV	7.1	6.3	3.4	Y	1000
0.18	ECHU1184□CV	7.1	6.3	4.0	Y	
0.22	ECHU1224□CV	7.1	6.3	4.8	Y	

↑ Cap. tol. code

### Recommended for Land Dimensions (mm)

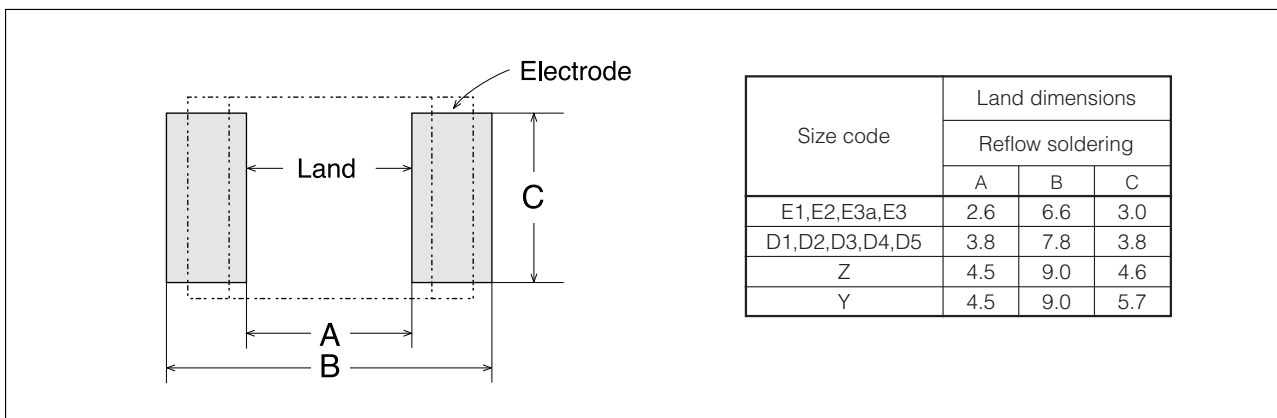

\* It is not warrantable that you can mount the capacitor without trouble under all the mounting condition when "Recommender for Land dimensions" is adopted.

**ECHU (C) Type DC100V series (Stacked Metallized Film)**

**Electrical Characteristics <Typical Data >**

**Temperature Characteristics**

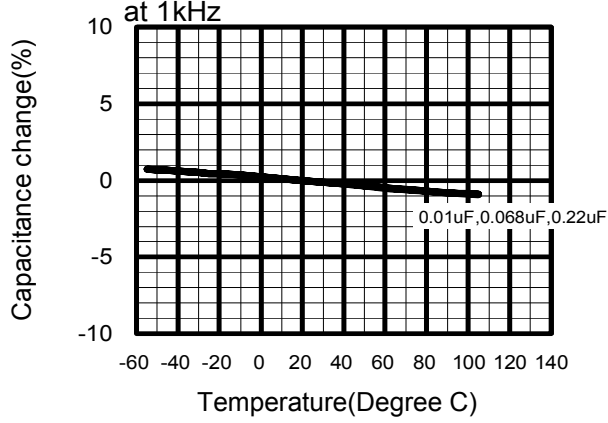

**Frequency Characteristics**

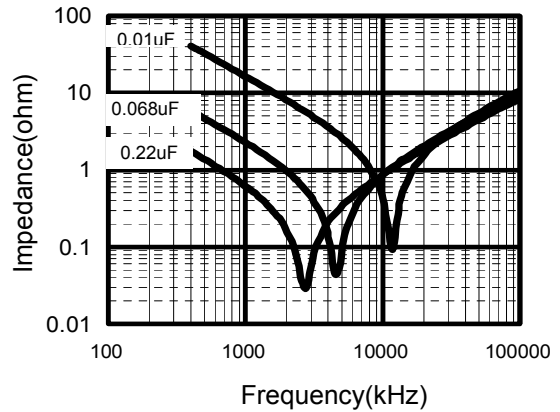
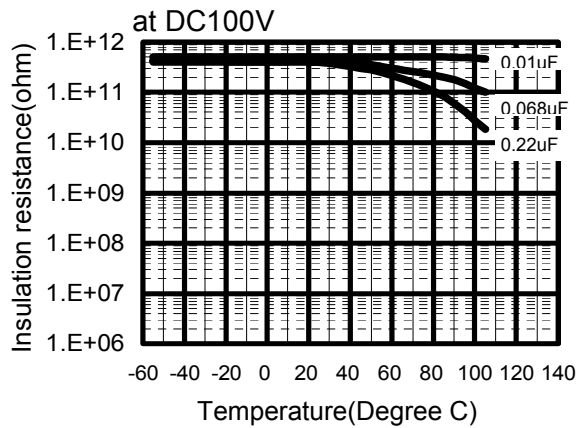
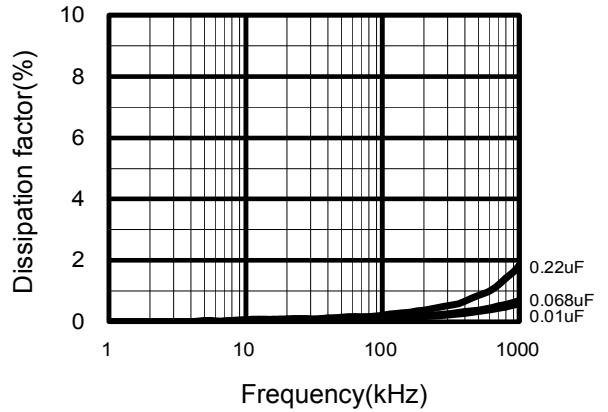
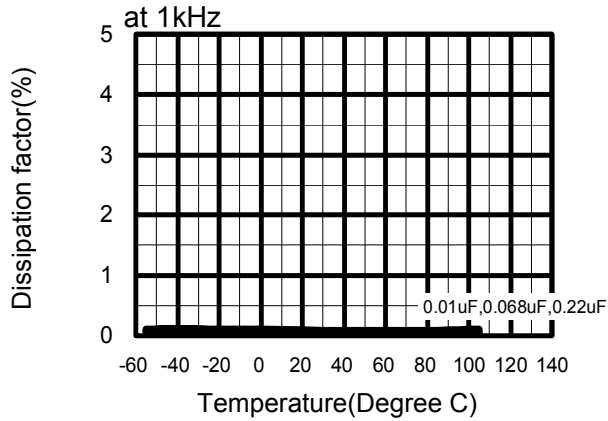
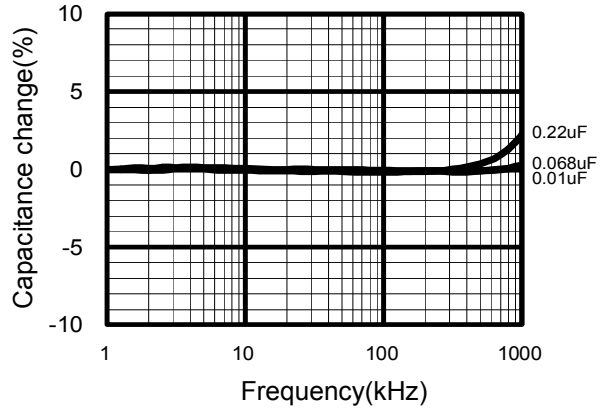

**ECHU (C) Type DC100V series (Stacked Metallized Film)**

**Applicable Specifications**

**Permissible Current**

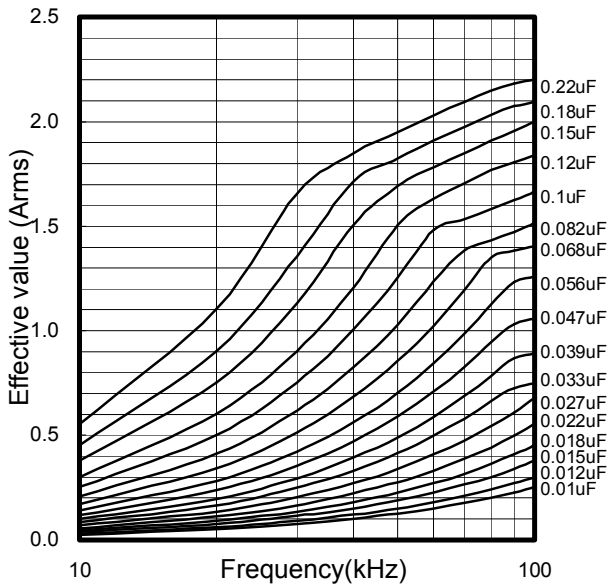

**Permissible Voltage**

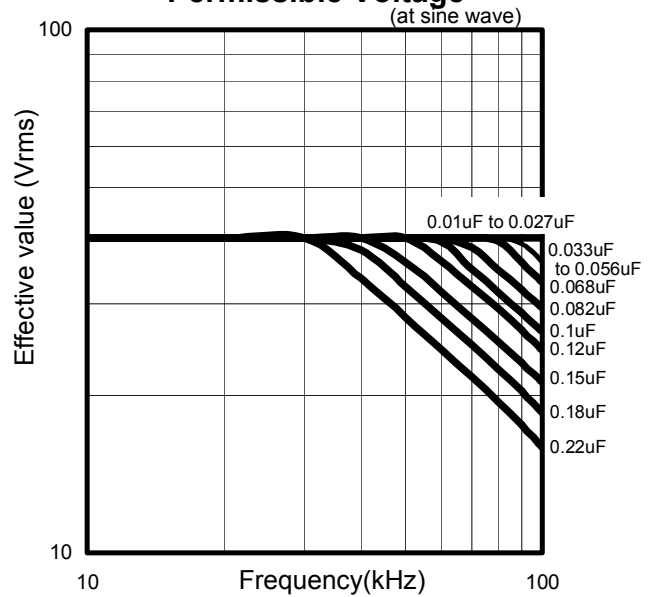

**Pulse Handling Capability (dv/dt)**  
(Max 10000cycles)

Rating Voltage	Capacitance Value(uF)	code	dV/dt (V/us)	Current(0-P) (A)
DC 100V	0.010	103	180	1.80
	0.012	123		2.16
	0.015	153		2.70
	0.018	183		3.24
	0.022	223		3.96
	0.027	273		4.86
	0.033	333	130	4.29
	0.039	393		5.07
	0.047	473		6.11
	0.056	563		7.28
	0.068	683	100	8.84
	0.082	823		8.20
	0.10	104		10.00
	0.12	124		12.00
	0.15	154		15.00
	0.18	184		18.00
	0.22	224		22.00

**Voltage Derating by Temperature**

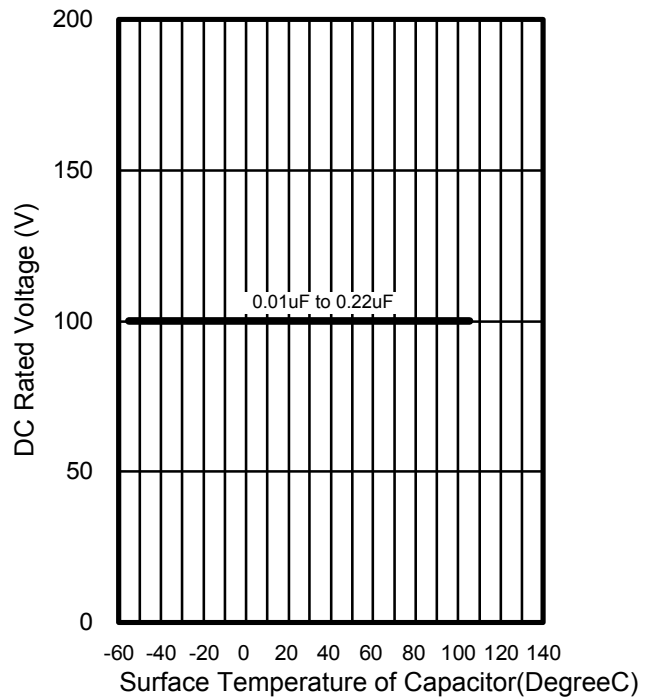

\*Please consult Panasonic if your condition exceeds the above

\*Permissible voltage graph is the case of sine waveform. When you use this product, peak voltage must not exceed DC rated voltage.

\*The current(0-P) value is calculated using nominal capacitance.

### 2.4.2 Cautions for use of soldering iron

- Be careful that the soldering irons do not directly touch the main body of the chip film capacitor. In particular, don't touch the side (cut section). If touched by the heated soldering iron, lowering of insulation resistance, shortcircuit or other characteristic deterioration may occur.
- Preheat the printed wiring board land sufficiently with the soldering iron, and then solder. Solder without directly touching the iron tip to the electrode of the capacitor.
- Don't reuse the products once removed by the soldering irons.
- Should not mount the chip film capacitors in the mass production by soldering iron. (The temperature control is difficult, and the characteristics may be deteriorated.)
- Should not resolder with heat directly from bottom side of P. W. Board. because capacitor will likely be damaged.

### 3. Washing the mounted boards

#### <Usable detergent and washing method>

(Usable detergent)

Classification	Detergent name	Maker
Alcohol derivative	IPA (isopropyl alcohol)	(Reagent for general industrial use)
Halogenated hydrocarbon	AK-225AES	Asahi Glass Co.

(Washing method)

Item	Condition	Temperature	Tine
	Immersion washing		50 °C
Steam washing		50 °C	Within 5 minutes
Ultrasonic washing		50 °C	Within 5 minutes

#### <CFC substitute detergent>

As a result of regulation of CFC and chlorine derivative detergents, many substitute detergents come to be used, but the performance of the chip type capacitor may be reduced depending on the type of detergent or washing condition. Check sufficiently beforehand. Consult us in advance if planning to use CFC substitute detergent.

#### <Drying after washing>

Dry after washing so that the detergent is not left over. If drying is insufficient, the detergent is left over on the element surface, and the insulation resistance is measured to be lowered. Dry enough so as not to leave detergent.

### 3.1. Washing of chip type

- Since the chip type capacitor does not have a coating, components of flux or detergent left over on the element at the time of washing may be activated and invade into the inside of the capacitor, and adverse effects may be caused. Observe the following cautions.
- In the case of washing, use flux and cream solder with halogen content of 0.1wt.% or less when mounting.
- In the case of ultrasonic washing, note that peeling of protective film, electrode separation due to resonance, or characteristic deterioration may occur depending on the detergent used or ultrasonic output. Check carefully beforehand.
- When using a CFC substitute detergent, with the washing method of spraying detergent (rinsing water) to the substrate at high pressure, the protective film on the element surface may be peeled off due to the water pressure. Check carefully beforehand.

### 3.2. Washing of leaded type

The film capacitor varies significantly in the effect of washing depending on the structure and material, and generally it is less affected by CFC or alcohol derivative washing solvent, and is likely to be affected by highly polar solvent.

The lead type film capacitor is coated with an epoxy resin excellent in chemical resistance, and is hardly affected by detergent, but it is recommended to be washed for short duration.

Applicability of detergents in film capacitors is listed for reference.

< List of applicability of detergents >

Washing condition		Chip type	Lead type	Box type	
				ECQUL	
Solvent	Alcohol	Ethanol Ultrasonic washing or immersion washing for 5 min			
		Isopropyl alcohol (IPA) Ultrasonic washing or immersion washing for 5 min			
	Silicon	FRW-17 Ultrasonic washing for 5 min, 60 FRW-1N Ultrasonic washing for 5 min, 60 FRW-100 Steam drying for 1 min, 100			
		Halogen	Asahi Clean AK-225AES Ultrasonic washing or immersion washing for 5 min		
	HCFC141b-MS Ultrasonic washing or immersion washing for 5 min				
	Petroleum hydrocarbon	P3 Cold Cleaner 225S Ultrasonic washing for 5 min 60          IPA ultrasonic rinsing for 5 min at ordinary temperature          hot air drying for 5 min, 40			
Toluene Ultrasonic washing or immersion washing for 5 min		×			
Terpene	Terpene Cleaner EC-7 Spray washing for 5 min at ordinary temperature          purified water spraying for 5 min, 50          hot air drying for 5 min, 80	×			
Water	Purified water	Ultrasonic washing for 5 min 60 wind-free drying          for 5 min, 85	×		
	Surface active agent	Clean Through 750H Ultrasonic washing for 5 min, 60          purified water ultrasonic washing for 5 min, 60          hot air drying for 5 min, 85	×		
		Clean Through 750L Ultrasonic washing for 5 min, 60          purified water ultrasonic washing for 5 min, 60          hot air drying for 5 min, 85	×		
		Clean Through 710M Ultrasonic washing for 5 min, 60          purified water ultrasonic washing for 5 min, 60          hot air drying for 5 min, 85	×		
		Clean Through LC-841 Ultrasonic washing for 5 min, 60          purified water ultrasonic washing for 5 min, 60          hot air drying for 5 min, 85	×		
		Ultrasonic washing for 5 min, 60          purified water ultrasonic washing for 5 min, 60          hot air drying for 5 min, 85	×		
		Shower washing for 1 min, 60          purified water ultrasonic washing for 5 min, 60          hot air drying for 5 min, 85	×		
		○ : Washing enabled	×	○ : Washing disabled	
				○ : Not confirmed	

< Wash-free flux >

Wash-free	Low residue flux	ULF-500VS			
	Inactivated flux	AM-173			

Washing disabled (x mark) detergent should be avoided because the appearance may be impaired, the characteristic may be deteriorated, and the reliability cannot be guaranteed